

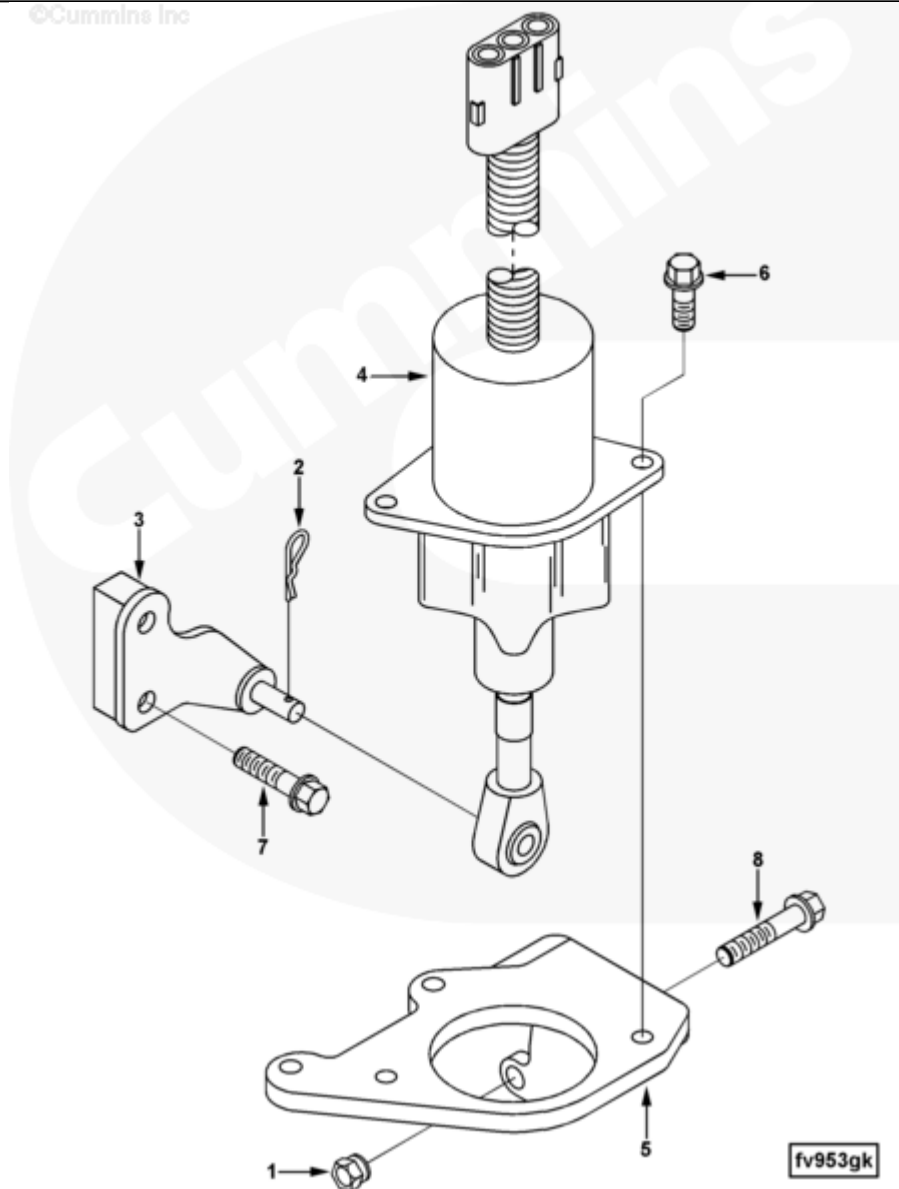

## Parts Catalog - Option Detail

Electronic Parts Catalog - Option Detail				
Option	Group	Graphic	Film Card	Date
FV9233	05.06	fv953gk	Z	31-MAR-99
Engines	6C8.3, C GAS PLUS CM556, G8.3, G8.3 CM558, GTA8.3 CM558, ISC CM2150, ISC CM554, ISC CM850, ISC8.3 CM2250, ISC8.3 G CM2180 C101, ISL CM2150, ISL CM554, ISL CM850, ISL G CM2180, ISL8.9 CM2150 L110, ISL8.9 CM2880 L112, ISL9 CM2150 SN, ISL9 CM2250, ISL9 CM2350 L101, ISL9 CM2350 L111, ISLE4 CM850, L GAS PLUS CM556, L8.9, L8.9 L121, L8.9G CMOH2.0 L125B, L9 CM2350 L116B, L9 CM2350 L119B, L9 CM2350 L120C, L9 CM2350 L123B, L9.3 L105, L9.5 L117, L9N CM2380 L124B, QSC8.3 CM2250, QSC8.3 CM2880 C102, QSC8.3 CM554, QSC8.3 CM850(CM2850), QSL9 CM2250, QSL9 CM2250 L115, QSL9 CM2350 L102, QSL9 CM2350 L107, QSL9 CM2350 L118, QSL9 CM2350 L122, QSL9 CM554, QSL9 CM850(CM2850), QSL9 G CM558, QSL9 M CM2250 L106, QSL9.3 CM2880 L113			



fv953gk

SMALL | MEDIUM | LARGE

Cart	Ref No	Part Number	Part Description	Required	Remarks
<a href="#">View My Cart</a>					
		FV9233	Fuel Shut-Off Valve		
					Valve Activation: Electrical
					Structure Code: 02 EBM
					Engine Design Phase: Current
					Product
					Voltage: 12
					Valve Manufacturer: Syncro-
					Start
					Solenoid Location: High
					Shutoff Valve Supplier:
					Cummins
					Solenoid Activation: ATR
					Unique Characteristics:
					Premium solenoid with
					standard connector
					Cylinders: 6
					Boot Type: Constant volume
					Solenoid Connection Type:
					Direct link spherical rod end
					bearing
					Shutdown Lever Hole Count: 3
					Solenoid Bracket Mtd
					Location: Fuel Pump Vertical
					Fuel Pump Manufacturer/Model:
					Bosch P300FV0923300
					Bosch P7100
					Pump Governor Type: RQVK
					Engine Family: B Series

					C Series
					DEP substitutes locknut
					3920893 for 3910959. Rod end
					and CV boot must not be
					painted.
					Solenoid requires 8.5V min
					for heat soaked activation.
<input type="checkbox"/>	1	<a href="#">3910959</a>	Lock Nut	1	M6 X 1.00.
<input type="checkbox"/>	2	<a href="#">3919449</a>	Cotter Pin	1	
<input type="checkbox"/>	3	<a href="#">3922832</a>	Shut-Off Valve Lever	1	
<input type="checkbox"/>	4	<a href="#">3935649</a>	Fuel Pump Solenoid	1	
<input type="checkbox"/>	5	<a href="#">3935653</a>	Solenoid Bracket	1	
<input type="checkbox"/>	6	<a href="#">3936683</a>	Hexagon Flange Head Cap Screw	2	M6 X 1.00 X 16.
<input type="checkbox"/>	7	<a href="#">3936684</a>	Hexagon Flange Head Cap Screw	4	M6 x 1.00 x 25
<input type="checkbox"/>	8	<a href="#">3936685</a>	Hexagon Flange Head Cap Screw	1	M6 x 1.00 x 30